



# Specifications

## DIVISION 2

### Fender Benders

Publication Date:

August 2024

## RSA Titles Policy

- On a state title event date for a RSA division, no race car registered for that division may race or practice at another venue on the same date using a logbook for the division that is holding the title.
- If a state title event is CANCELLED or POSTPONED for any reason and re-scheduled for a later date, the above restriction does not apply to the re-scheduled date (i.e. if the title event moves to another date, race cars registered for that division may race or practice at another venue on the re-scheduled date using a logbook for the division that is holding the title).
- Dual-registered race cars may race or practice using a logbook for a division that is not holding a title on the same day.
- Roof numbers may be changed to avoid duplicate numbers, car numbers must be displayed on front sun visor and rear taillights/ boot lid - minimum height 75mm.

# RSA DIV 2 FENDER BENDERS SPECIFICATIONS

## Introduction

- a) Racing Sedans Australia (RSA) shall direct the enforcement of these specifications in every aspect. The RSA Executive Committee in consultation with the RSA Div. 2 Chief Technical Officer and Technical Advisor/s shall together be the authority for the interpretation of these specifications contained within and any further amendment, clarification, alteration or addition.
- b) Any amendment, clarification, alteration or addition of, or to these specifications will be sent to all RSA clubs (electronic / post) who shall then pass on the relevant information to their competitors and membership as required.
- c) This specification book supersedes all others, and no reference is to be taken from any previous books regardless of their contents. Any amendment or clarification will be sent to all clubs (electronic or post) who in turn will notify all their competitors/members.
- d) DIVISION 2 – FENDER BENDERS - CONTACT PERMITTED. Direction of racing may be either way as per club and/or track requirements.
- e) **NOTE:** *This book is to be read and referenced in its entirety. Whilst every effort has been made to have all relevant information pertaining to all issues contained in one area, paragraph or page of this book for quick reference and guidance, it may not have always been practical, possible or achievable for that to have had occurred.*

The contents of this book may not be copied or reproduced in any way without the written authority of Racing Sedans Australia Incorporated.

# Table of Contents

1) INTERPRETATION .....	5
2) SAFETY STANDARDS .....	7
3) IDENTIFICATION NUMBERS .....	8
4) INSTALLATION OF DRIVER RESTRAINT SYSTEM .....	9
<b>Seats</b> .....	9
<b>Seat Belts</b> .....	10
<b>Seat Belt Mountings</b> .....	10
<b>Seat Belt Installation Guide</b> .....	10
5) FIRE EXTINGUISHER .....	12
6) WINDOW NET .....	12
7) BATTERY .....	13
8) ELECTRICAL WIRING .....	13
9) MIRRORS / CAMERAS / TRANCIEVERS .....	13
10) STARTER MOTORS .....	13
11) BODIES .....	14
12) BUMPERS .....	16
13) FIREWALL .....	18
14) RADIATORS .....	18
15) EXHAUST SYSTEM .....	19
16) FUEL TANK / LINE / TAPS .....	19
17) FUEL .....	20
18) ROLL CAGE .....	20
<b>Anti-Spear Plate</b> .....	29
<b>Foot Protection</b> .....	29
19) SUSPENSION .....	30
20) WHEELS/TYRES .....	31
21) WHEEL ARCHES .....	31
22) BRAKES .....	31
23) PEDALS .....	31
24) STEERING .....	31
25) TRANSMISSION .....	32
26) DIFFERENTIAL .....	33
27) ENGINE .....	33
28) EFI ENGINES .....	34
29) CARBURETTOR .....	37
30) WINGS .....	38
31) SPOILERS .....	38
Appendix 1 – Limited Approvals 2024-25 season .....	39

## 1) INTERPRETATION

- a) Specifications listed in this book are meant as a guide only to building race cars unless otherwise specified. **If "IT" is not mentioned in this book**, enquire beforehand for clarification and / or possible approval.
- b) Before constructing any race vehicle, or adding any part, panel or component thereof of unusual, unconventional or unknown design, full details are to be submitted in writing to the RSA. These submissions are to be with supporting documentation of the issue/s and come via your club to the RSA secretary for processing. A written response will be provided, and if approved, the letter of approval is to be attached to the car's logbook. Prime consideration must be given where any doubt exists, to safety of Drivers, Crew, Officials and Spectators.

**Note: It may not always be possible for RSA Committee persons and / or Tech Advisors / Officers to provide an immediate verbal or written response to queries relating to specifications.**

- c) Prime consideration must be given where any doubt exists, to safety of Drivers, Crew, Officials and Spectators.
- d) It is recommended, whenever possible, that all race cars under construction be inspected by the licensed Club Scrutineer before painting.
- e) All race cars are subject to engine and general measurement before and after any race at the discretion of the Chief Steward, Technical Officer, or Disputes Committee. Any question of legality of a race car, or eligibility of a race driver, must be settled before the commencement of a race meeting.
- f) Notwithstanding anything contained in these specifications or any other Supplementary Regulations that have been approved by the Racing Sedans Australia Inc (RSA), the Scrutineer shall have the right to exclude any vehicle if it is not track worthy, fails to meet specifications in relation to safety or performance advantage, or could become a danger to other competitors or the public or is not constructed in an acceptable manner.
- g) The Scrutineer will make a full report in the Car's Logbook and all defects noted must be rectified before the car is presented for scrutineering again or the vehicle may be excluded from the event.
- h) All material sizes mentioned here within are a minimum unless a maximum is stated. Any Part, Panel or Component not specifically mentioned to be modified must remain standard as per production base model.
- i) Ignorance of Speedway Australia Rules and Regulations and this RSA Div. 4 Specification book and notices shall be deemed as no defence in regard to breaches and/or appeals of same.
- j) Race cars must maintain a neat and presentable appearance, so as not to bring disgrace to the Association. All body panels, bumpers, exhaust systems, etc., must be securely mounted. Any driver who continually loses components on the racetrack will be liable to a fine and/or suspension.
- k) All cars are to be built and repaired to a high standard. All material used is to be of high quality. No bolts/rivets/screws or holes of any sort are to be put in any structural tubing in the roll cage cabin area.
- l) Race cars, when presented for scrutineering, must be in full race condition (i.e. tyres to be used for racing, battery secured, helmet, full race clothing, bonnet and boot may be removed for ease of scrutineering).

- m) Any driver who continually loses components on the racetrack will be liable to a fine and/or suspension.
- n) It is the responsibility of all drivers to ensure their race cars have all sharp protrusions removed when presenting them for any race. The Scrutineer may at any time, direct a driver to remove sharp protrusions, and this must be carried out before entering the track.
- o) Car registration (green sheeting) and payment and issue of an annual / seasonal RSA logbook are required before competition. **Registration of an RSA Vehicle cannot be made by a person under the age of 18 years.**
- p) It is the driver's responsibility to make sure that his/ her car and all internal and external engine components meet the specifications of this Division. Pre-race and post-race vehicle scrutineering inspections may be performed at any race meeting, including state and national titles. If any car fails the after-race specification inspection the driver will be fined / suspended and / or disqualified from the event under Speedway Australia's Racing Rules & Regulations.
- q) **RSA head gasket refund policy:** If the vehicle is found to comply with RSA specifications for the division after post-race scrutineering the RSA will either:
- Directly pay for OEM or standard after-market equivalent parts from an RSA nominated supplier, or
  - Provide a refund that is equivalent to the RSA's cost for supplying replacement parts.

**NO REFUNDS** will be paid for any vehicle that is found to be in breach of RSA Specifications for the division.

- r) Vehicles may have fuel checked at any time during the course of any race meeting including state and/or National titles.
- s) Any driver found with any debris in cabin, boot or pockets, etc. (i.e.: broken glass, bolts, tools etc.) will be refused race clearance to enter the track until the offending items are removed.
- t) Long hair must be fully contained within suit. No cigarettes / lighters or similar allowed on or used by driver whilst in the race car and / or to track pit requirements. No asthma puffers allowed on driver whilst in the race car. Jewellery that could cause injury (e.g. dangling earrings) is not to be worn.
- u) Drink bottles (plastic) permitted – maximum size 2 litres. The drink bottle must be suitably and firmly mounted behind driver and to be to the Scrutineer's satisfaction.
- v) **NOTE:** RSA will not accept, recommend, or endorse any 'homemade' modifications / alterations to any suspension component/s or to any other OEM vehicle parts. Any fabrication / alteration allowable within these specifications to these items is to be performed only by persons who are certified specialists in their field of expertise in regard to modifications / repairs to the respectively noted equipment.
- w) RSA Inc. reserves the right to impound and inspect any race car at any time; this may include the removal of any engine for inspection and including the downloading of any information via relevant means if applicable. Cars can be selected at random and ordered to the impound area for dismantling. The Owner and/or Driver of the car must deliver them immediately upon request and supply the necessary manpower and hand tools to accomplish dismantling. Only 2 x persons actually involved in dismantling the car will be allowed in the immediate area of a vehicle being checked. Any persons not having cars in the impounded area, and gaining entry without authorisation, will be ejected.

## 2) SAFETY STANDARDS

**Note:** These are the minimum only safety standards for racing apparel of which may be subject to change at any time. Refer to your local club and/or [www.speedwayaustralia.org](http://www.speedwayaustralia.org) for current up to date regulations and notification of any changes. At the time of publication, the following standards were applicable (copied from Part 16 of Speedway Australia Racing Rules & Regulations, v.24/25.1 version):

### APPLICABLE LICENCE CATEGORIES

- **A** All Sedan Divisions
- **B** All Divisions
- **JD** Junior Competitors except Jr F500's

#### 16.1) Race Suit

Minimum standard of a 1 piece complying with either SFI 3.2A/1, FIA 8856-2000, FIA 8856-2018 or a higher standard of apparel.

#### 16.2) Boots

Comply with SFI 3.3, FIA 8856-2000 or FIA 8856-2018. Socks must comply with SFI 3.3, FIA 8856-2000 or FIA 8856-2018.

#### 16.3) Balaclavas

Comply with SFI 3.3, FIA 8856-2000 or FIA 8856-2018 and must be worn

#### 16.4) Gloves

Comply with SFI 3.3, FIA 8856-2000 or FIA 8856-2018. It is recommended they are the Gauntlet style glove, and they must not be modified in any way.

#### 16.5) Underwear

Must be worn and comply with SFI 3.3, FIA 8856-2000 or FIA 8856-2018, must be long sleeved, long legged and must have a neck collar. Drivers must only wear cotton under-garments (e.g., no synthetic boxer shorts), and no under wires on bras. No synthetic attire and no jewellery to be worn by a competitor whilst competing.

#### 16.6) Helmets

Tozuda head impact indicators are optional.

**Note: RSA recommendation only and is not part of the SA safety rules**

Full faced and comply with one of the following:-

- 1) Snell SA2025 (to be introduced October 1st 2025)
- 2) Snell SA2020
- 3) Snell SA2015 (Note: Snell SA2015 Standard Helmets cannot be used after July 1st 2026)
- 4) FIA 8858-2010
- 5) FIA 8859-2015
- 6) FIA 8860-2010
- 7) FIA 8860-2018

For JD (Junior Divisions) only, the following helmets are also approved for use.

- 1) SFI 24.1
- 2) CMR2016
- 3) CMS2016

**NOTE:** All BS 6658-85 Type A/FR, AS/NZS 1698:2006 or UN ECE 22.05 standard Helmets cannot be used after 30 June 2024.

### **16.7) Horse Collar**

Compulsory if Driver is not using a Head and Neck Restraint. Must comply with SFI 3.3.

### **16.8) Head and Neck Restraint**

Recommended but not mandatory. If worn a Head and Neck Restraint must conform with FIA or SFI 38.1.

Please note that SFI Spec 38.1 Head & Neck restraints must have an in-date compliance sticker on them. The SFI 38.1 Spec requires them to be re-certified every five years. Competitors and officials please take time to check the dates on all Head and Neck Restraints to ensure compliance with these rules.

- HANS Device Recertification Revolution Racegear [www.revolutionracegear.com.au](http://www.revolutionracegear.com.au)
- Safety Solutions / Simpson Hybrid + variants & R3 Frontal Head Restraints Simpson Safety Equipment Australia [www.simpsonraceproducts.com.au](http://www.simpsonraceproducts.com.au)

### **16.9) Arm Restraints**

Arm restraints must be worn in all classes where a window net is not fitted. Must comply with SFI 3.3 or FIA. Where a window net is used, it must comply with SFI 27.1 or FIA J253.11 and comply with expiry dates/replacement periods.

## **3) IDENTIFICATION NUMBERS**

- a) All race cars must carry the correct identification number as is issued by their club. The numbers must be displayed on BOTH front doors, rear doors or quarter panels. Numbers on doors are to be a minimum height of 40cm high x 7 cm wide strokes, on rear quarter panels minimum 30cm high x 7cm wide strokes, in a contrasting colour and easily read by officials. Club prefix to be minimum height of 10cm high x 2 cm wide strokes. club prefix optional. IE: Grafton = GCSC.
- b) Car number must also be displayed on windscreen visor and rear taillight/Boot lid. Minimum height 75mm.
- c) Drivers will use upright roof numbers of no more than 16G material, 300mm x 300mm in size - Number must be white on black background. If a top wing is fitted (refer wing section), the roof number may be incorporated on wing (both sides) but must be to the above noted requirements and be made clearly distinguishable amongst any other noted sponsorship signage or wing colouring. A clear border around the number area may be required.
- d) Visiting drivers with conflicting car numbers will alter their roof numbers as notified when it is required for lap scoring purposes. Failure to comply will be dealt with by the Chief Steward.
- e) Drivers' name is to be placed above right-hand front door or on sun visor minimum height 7cm.



- f) Current RSA registration / logbook decal must be affixed to the roll cage / cabin area within easy view for verification.

#### 4) INSTALLATION OF DRIVER RESTRAINT SYSTEM

In order for the driver restraint system to be fully effective, considerable thought must be given to the location of mounting points and to proper installation. Many installations comply only with the letter of the rule with no understanding of the purpose, and although effective, to some degree, may cause needless injury to the driver.

##### Seats

- a) A purpose-built, one piece, Steel or Aluminium bucket type seat and headrest must be used. Seats may be padded and covered with a fire-resistant type material, the covering being securely attached - maximum thickness 50mm. NO fiberglass or plastic seats allowed.
- b) Minimum of 50mm clearance between helmet and head plate.
- c) All seats should be mounted as per manufacturer's installation instructions.
- d) Seats must be either:
- mounted directly to the roll cage or seat frame of roll cage material (minimum 38mm OD x 3mm WT CHS) and/or 50mm x 50mm x 3mm angle iron or stronger or,
  - mounted to the roll cage or seat frame of roll cage material (minimum 38mm OD x 3mm WT CHS) and/or 50mm x 50mm x 3mm angle iron or stronger using the manufacturer's seat mounts for the seat being used.
- e) The seat must be suitably supported by a minimum of 50mm backing plate or washers (to prevent bolts pulling through seat). A minimum of 4 x 8mm bolts must be used - 2 upper (e.g. in seat back) and 2 lower (e.g. in seat base or sides). All seat bolts must be of cup-head design.
- f) All cut-outs for seat belts must be suitably grommeted. No sharp protrusions allowed.
- g) Head rest must be at least 100mm wide. (Cover with suitable material optional).
- h) Side supports to be a minimum of 50mm on all seats at thighs and torso areas. Seat is to be a correct fit for driver.
- i) Side head/shoulder support restraints optional – manufacturer's recommendation on fitment.

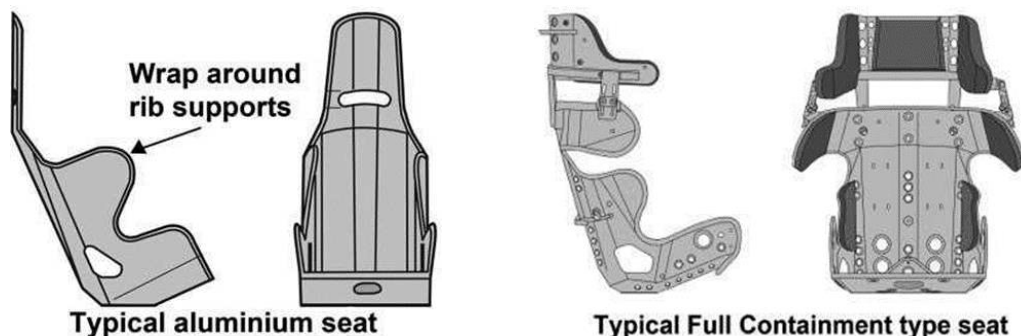

## Seat Belts

- a) All race cars must be fitted with a 5 or 6 mounting point racing harness of the lever latch style, which must be certified by an authoritative body (such as SFI) and must conform to all of their policies including fitment and care/maintenance. Any worn, frayed, rotten or weld spotted holed seat belts are not acceptable, and race cars will not be allowed to enter the track until the seat belts are replaced.
- b) Seat belts must be no older than 2 years from the date of manufacture. Date of manufacture and/or expiry date must be clearly marked on a manufacturer-fitted identification tag.
- c) Belts, including crotch strap must be a minimum width of 50mm (2 inch).
- d) All seat belts must be mounted in such a manner to allow their removal between race meetings or when working on the car.

## Seat Belt Mountings

- e) Because of the difference (often vast) in competition race cars and size of drivers, a standard method of mounting is impractical. Good judgment and common sense are needed. The lap belt should be positioned so that it rides across the solid pelvic area and not the soft stomach area or down on the thighs. Seat belts must be mounted to roll cage. Mounting brackets must be welded to roll cage or roll cage cross braces only. Mountings to be equivalent or stronger than roll cage material or 50mm x 50mm x 3mm angle iron. Any race car found with bolts through seat belt webbing will be immediately given an order to replace seat belts. Rear anchorage must be mounted so as to prevent side movement by harness. Scrutineer may require the fitting of a rear harness loop.
- f) MINIMUM 10mm bolts to be used.

## Seat Belt Installation Guide

- g) The purpose of this guide is to provide race car drivers, owners and mechanics with additional information on seatbelt installation for upright seats (up to 25° recline seat back angle). This guide is for informational purposes only.

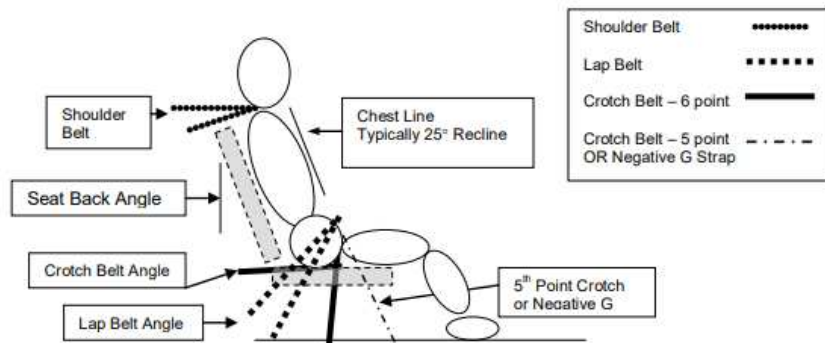

### SHOULDER BELTS

Shoulder Belt Angle: 0 to -20° (-10° optimum) from horizontal

- Clear passage of webbing from top of shoulder (or head and neck restraint) back to the harness bar or mounting point without any interference of the seat openings
- Belts should be as short as possible back to the mounting points

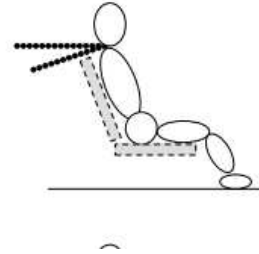

### LAP BELTS

Lap Belt Angle: -45° to -80° from the horizontal

- Belt should ride within the curvature of the pelvic bone preferably just below the iliac crest
- There should be clear passage through the seat opening without webbing being corded or binding on edges of seat openings with a direct path to the mounting point
- The webbing should not ride against any hardware such as seat mounting brackets, bolts, or tabs
- Lap belt adjusters should be clear of the seat openings. Pull-up adjusters if outside the seat opening should be a minimum of 2" below the opening when the lap belt is tightened

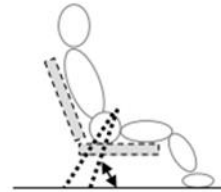

- Belts to the mounting point should be as short as possible mounted beside the seat and never behind the seat
- Lap belt should be allowed to pivot freely at the mounting point
- Webbing should be allowed to pull on hardware in plane (straight)

Position of the Cam Lock or Latch and Link

- Centered on the body 1 to 2 inches below the belly button when all belts are tightened

### CROTCH BELT – 5-POINT

Sports Car “Shell Type Seat” and aluminum seats with single crotch belt hole forward of the inside seat back from 11 to 13 inches:

- Crotch Belt Angle: Chest line to 20° through the hole
- Crotch Belt should never wrap around the front of the seat – there should be a pass through
- Crotch belt is used only to maintain position of the lap belt

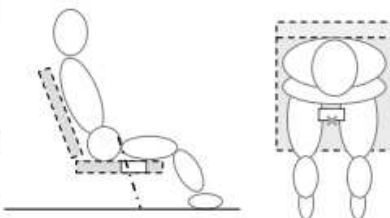

## CROTCH BELT – 6-POINT

Sports Car “Shell Type Seat” and aluminum seats with single crotch belt hole forward of the inside seat back from 10 to 12 inches: (*NOTE: Seats with a single hole positioned more than 12 inches from the inside seat back are designed for 5 point belt installations and may not be as effective for 6-point installations*):

- Crotch Belt Angle: -20° (2” rearward) through the hole
- Two separate anchors 4 to 6 inches apart (x)

Containment Seats with Crotch belt mounting directly to seat bottom OR through holes provided at the back of the seat bottom: (*Driver is sitting on the Crotch belts*)

- Crotch Belt Angle -10° to -20° from the perpendicular just in front of the crotch with anchors 4 to 6 inches apart (x)

OR

- Crotch Belt Angle Horizontal rearward to under the butt or to the back of the seat (x)

Option (typically for single-seat wide cockpits):

Crotch Belt mounting to the front side of the outboard lap anchors. (Option not illustrated)

Considerations:

- Routing of crotch belts should have a clear and unobstructed path to the mounting point

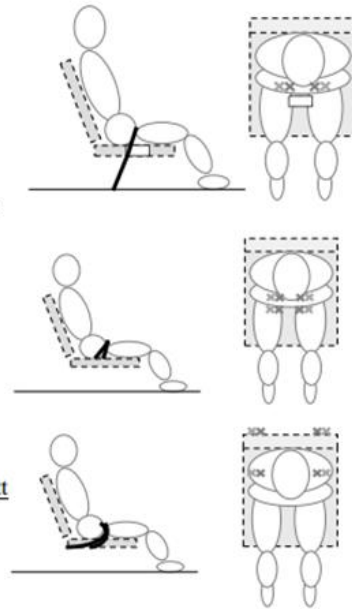

## 5) FIRE EXTINGUISHER

An on-board fire extinguisher is permitted. It must be securely mounted and be suitable for the fuel being used.

## 6) WINDOW NET

The use of an SFI approved window net is mandatory. It must comply with SFI 27.1 or FIA J253.11 and comply with expiry dates/replacement periods (Speedway Australia rule).

- All race cars must be fitted with a propriety type (i.e. a well-made, either from a race wear manufacturer or made by an upholsterer) web style window net (i.e. no string nets and no steel mesh). The window net should, as near as practicable, cover the drivers' side window opening. Triangular window nets are not permitted. Maximum size of holes to be 75mm x 75mm.
- All window net mounting brackets must remain inside window and door frames. The purpose of a window net is to stop the head or arms coming outside of the car in an accident or roll-over. Window net must be easy to remove in case of an accident. Window net **MUST** be hinged from the bottom.
- Must be securely mounted top & bottom to avoid coming loose in an incident.
- Window net must be mounted to the roll cage using brackets, using minimum of 3mm steel plates and a minimum of 6mm steel or 10mm aluminium rods, and mounted so that it cannot be pushed outwards.
- Top mounting rod must be manually removable (i.e. without using tools). Examples of this are: spring-loaded fitting, seat belt style fitting, R clips etc. If using a spring-loaded fitting, it must have sufficient tension to avoid it coming loose in the event of an impact.
- Ocky straps not permitted.

## 7) BATTERY

- a) Battery must be securely fastened in a steel frame in the cabin area. After market weld on/bolt on battery bracket (e.g. Kenco weld on or bolt on steel battery box clamp) permitted. No plastic bridges.
- b) All batteries (sealed batteries included) must have an effective rubber cover placed over the top to prevent acid spilling in the event of a roll-over. Rubber grommets must be fitted where battery cable passes through metal firewalls.

A highlighted blue triangle is to be placed on outside of car body to show battery location. A white bordered blue triangle permitted for contrast on blue or similar coloured cars.

## 8) ELECTRICAL WIRING

- a) All switches to be grouped together within easy reach of driver with seat belts fastened and clearly marked on/off.
- b) A 'kill switch' must be fitted outside the windscreen in the centre of the cowl panel or on the front of roll cage windscreen centre bar to control all electrical circuits and must be clearly marked on/off in a contrasting and distinctive colour. Dipper switches may be used and it is highly recommended that a 'fairy light' be used to indicate when power is on/off. No other lighting to be fixed to any other body panels or external of vehicle. Electrical wiring must be grommited where it passes through firewalls etc. and taped to prevent chaffing.

## 9) MIRRORS / CAMERAS / TRANSCIEVERS

- a) Mirrors of a standard type car mirror only are permitted. To be fitted securely to the centre of the roll cage on the top windscreen bar.
- b) **No** electronic device / screen or similar, capable of receiving live transmission from rear, side or front facing cameras **to driver** permitted in any shape or form whatsoever. Penalties will apply.
- c) One-way steward to driver communication devices (raceceivers) and lap scoring transponders are permitted. All other radio or similar telemetry to or from a car is not permitted.
- d) The use of one-way in-car communications is compulsory for all drivers.
- e) Small electronic recording devices (cameras) are permitted on vehicles but need to be securely mounted within the cabin area. Various configurations and designs may need prior approval before fitment. Any in car camera can only be mounted on a helmet if the helmet manufacturer guidelines allow it.

## 10) STARTER MOTORS

At the commencement of the race meeting, car must be capable of starting by an installed starter motor.

## 11) BODIES

- a) Sedans, station wagons, coupes, hatchbacks and utilities permitted. Full chassis cars convertibles, panel vans or utilities with wooden floor trays not permitted. Bodies up to 1996 may be used Engine must be mounted in original position without modification.
- b) All vehicles to be a production model of a series as it came off the production line. Vehicle must be the same dimensions and appearance as of model.
- c) Original body panels to be used and must be in sound condition NO fiberglass panels permitted.
- d) All glass, external mirrors, grills, door handles, door mechanisms, ornamentations, bull bars, tow bars, helper springs and flammable material to be completely removed, together with manufacturers fuel tank. Light and body apertures MAY be filled in with 1.6mm sheet steel(maximum), body metal or rubber. Doors to be securely bolted or welded. Boots to be pinned, chained, strapped or bolted.
- e) Bonnets if hinged to be securely fastened. To be pinned, chained, strapped or bolted on two corners. Bonnet if not hinged to be pinned, chained, strapped or bolted on all four corners. Bonnet pins and bolts are to be a maximum 25mm and are not to be attached to the sub frame or chassis in any way. Hold down plate to be a maximum 100mmx100mmx3mm.
- f) A protective mesh must be fitted to the driver's side of the windscreen. Mesh to be up to maximum 5mm thick x 50mm x 50mm or 50mm x 75mm maximum. There must be a clear vision area in front of the driver of at least 200mm. Name plate may run width of front windscreen, maximum depth at centre of windscreen 200mm. **Windscreen mesh may be welded to roll cage or attached to roll cage using metal clamps, minimum 4 clamps (2 on each side) for single-side mesh or minimum 6 clamps (2 on each vertical roll cage bar) for full windscreen mesh in divisions which allow this option for 2-seaters. Must be mirrored on passenger side bar work if passenger seat fitted.**
- g) **Additional windscreen mesh option for 2-seaters:**

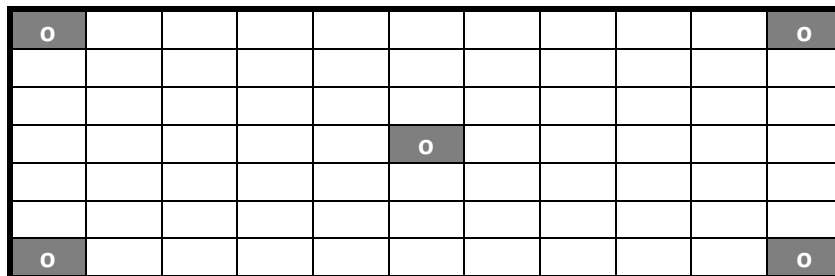

A one-piece removable windscreen mesh covering full width of windscreen and attached to roll cage by 5 pins and clips or snap rings is permitted as an option:

- Outside border: Minimum 5mm steel rod shaped to fit into the original windscreen channel on the car body.
- Internal mesh: 3mm to 5mm, 50mm x 50mm or 50mm x 75mm steel mesh.
- Metal plates: 5 x minimum 3mm steel plates fully covering one square of the mesh to be welded in – one in each corner and one in the centre as shown.

- Pins: 5 x 10mm to 15mm steel pins to be welded to roll cage at one end and go through the metal plates to hold the mesh in place with clips or snap rings.
  - R-clips or snap rings: 5 x minimum 3mm R-clips or snap rings in – one in each corner and one in the centre.
- h) Dash maybe removed, providing it does not weaken the body.no skeletonizing is permitted, with the exception of the driver’s side door for nascar bars. Window frames to be welded in at least three places, 25mm long minimum.
- i) Driver’s side front floor **only**, may have one drainage hole, maximum 30mm all other holes must be filled in.
- j) A steel mesh grill maybe used (expansion plate, hollow plate or catwalk type mesh not permitted) maximum thickness 5mm steel x 50mm x 50mm or 50mm x 75mm. grill to be no wider than radiator opening. Door skins maybe removed for panel beating but must be securely replaced.
- k) Headlight plate may be attached to the top of the front bumper-2mm maximum plate to be used.
- l) A full sheet plate may be used out of maximum 2mm thick, can be from headlight panel to headlight panel or as a grill infill if headlight panels are already plated. Must be attached to the radiator support panel and go down as far as the bottom radiator support panel. These extended grills must NOT be attached to the chassis rails and ONLY stitch welded to the radiator support frame and headlight surround.
- m) **No plate to below the top of the bumper bar. No overlapping and stitch weld only.** Steel plate grill is **only permitted in** cars with steel bumpers. Cars with front bar work can only run mesh grills.
- n) **No Tek Screws or Self Tappers to be used in construction.**
- o) **No ballast permitted.**
- p) If roof is removed during race car construction (e.g. to install roll cage), it must be fully welded (inside and out) when it is reattached. Additional reinforcing plates across joins are recommended.
- q) Side mirror frame and/or front and rear quarter window frame (if fitted) may be filled in only – NO partial or full fill in off any other side / front or rear windows permitted unless noted otherwise. Diagram below.



## 12) BUMPERS

- a) Must be original front and rear or of similar appearance. Plastic or polycarbonate bumper bar may be replaced by a steel bumper bar or similar shape and appearance. To be attached only to the sub frame, a standard bracket may be plated with MAXIMUM 3mm on the top and bottom only, once the original bracket is destroyed a replacement bracket may be built out of manufactures equivalent e.g.: 3mm flat bar designed the same as original. Can only be welded 150mm from ends. **Not fully welded to the car or stitched welded width of bumper bar.**
- b) No reinforcing what so ever permitted.
- c) Plastic or Poly-carbonate bumper bars as per model permitted. Plastic or Poly-carbonate bumper bars may have a flat bar of 40mm wide x 3mm thick (maximum) may be placed on the inside and outside from end to end of the width of the bumper bar.
- d) Extension on bumper bars not allowed. Ends of front and rear bumpers are to be attached to front guards and rear quarter panels to stop getting hooked. Maximum material permitted - 1.6mm x 150mm by width of bar, using cup-head bolts or welded. The purpose of this is for securing bumper bar only. XD, XE and XF Falcons may use an XC Bumper Bar, or RSA approved bar. All XC brackets must be used and corners securely attached to mudguards. Maximum material permitted - 1.6mm x 150mm x width of bar, either welded or bolted using cup head bolts only.
- e) If bumper bar is shortened, it is to be butt welded not overlapped and welded.
- f) Fender benders to run front bar work see diagram for models that run plastic bumper bars.
- g) Rear bar work on fender bender for models running a plastic bumper bar excluding outer bar work if using steel bumper bars. Bumpers:

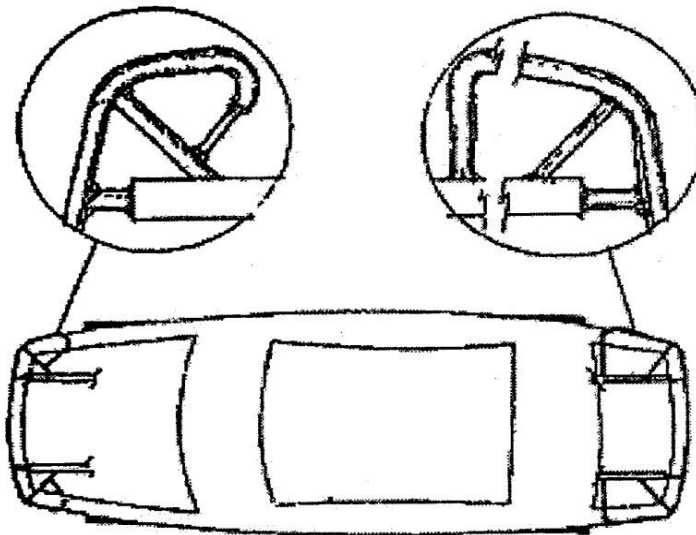

- h) C channel bumpers to be a maximum of 200mm deep and 2.4mm thick, can have 1 join but welded no over lapping or re-enforcing, fit to one side of car notch top and bottom of the C channel where you need to bend, put a pipe in behind to get desired smooth roll around the corners to prevent sharp points/ spears may go from wheel arch to wheel arch, this will accommodate for newer model cars where bumpers wrap right around, whilst also giving your quarter panel a push bar, can be fully welded to quarter, minimum of 7x cup head bolts e.g. 2x



in each quarter panel and 3 along rear. bumper ends near wheel arch to be tapered to original body line of car and filled to stop sharp points.

- i) Same to be used on the front out of the same material and design- no bumper strengthening.
- j) May use steel bumper on one end of the car and barwork and plastic bumper on opposite, may be used on any one car together.

### 13) BOOT BARWORK

Material: Roll cage material to be used. Maximum 38mm x 3mm CHS

- a) All corners to be rounded.
- b) Bar to lay on the floor of the boot and loop around in the rear quarters. Can be made into a fuel cradle or can be 2 separate pieces each side of the boot. Must remain in the boot and not protrude outside the car. Barwork to be bolted through the floor securely. No extra bars to be added just as per diagram.

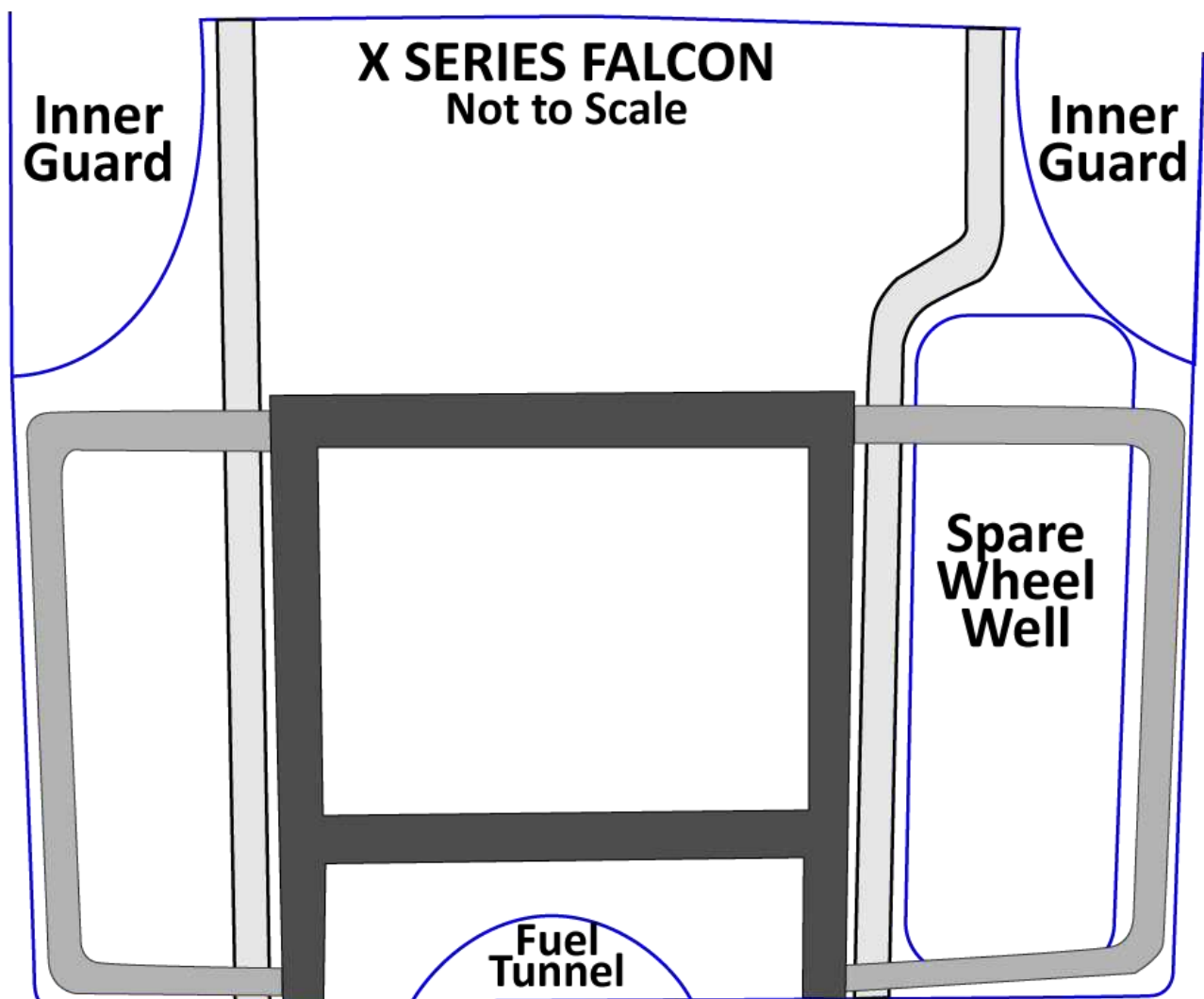

## 13) FIREWALL

- a) Drivers must be isolated from mechanical, fuel, electrical and exhaust components by firewalls of minimum 0.9mm steel or aluminium. Standard firewalls (front and rear) must remain in original position.
- b) All holes in firewalls must be filled with suitable material. Small holes (up to 3mm) and small gaps around wiring and radiator pipes may be filled with fire resistant sealant. Larger holes to be filled with minimum 0.9mm steel or aluminium.
- c) Rear firewall and parcel shelf to be covered with min 0.9mm steel or aluminium secured with bolts, pop rivets or welded.

## 14) RADIATORS

- a) Two (2) maximum per car. May be in original position and/or rear of cabin area only (to be no further forward than main roll cage hoop). If in rear only, no support bars permitted in front. One (1) only allowed in front of car. No cutting out of the body to make it fit. Fans are **optional**, plastic or steel. Fans must have a shroud or suitable guard.
- b) Radiator mounted inside the cabin must be as low as possible in rear of vehicle. The top of the radiator and shrouding must not protrude above half rear window height. Radiators **must** have a suitable shield around the tanks (front and back, top and bottom, left and right), to ensure the driver and other persons are protected in the event of radiator failure or caps blowing. Pipes leading to the radiator must be steel, aluminium or copper pipe, **poly- pipe or re-enforced pressure hose not permitted**. If a professionally fabricated aluminium racing radiator is used with the tanks TIG welded to the core, the tanks are not required to be covered, but radiator cap must be covered. Examples of this are racing radiators produced by KENCO and AFCO.
- c) Pipes are to be securely fastened inside roll cage in such a manner that they cannot be flattened or punctured in the event of a collision.
- d) **Pipes must run through cabin area - not under car.** All internal pipes and radiator hoses from the front firewall to the tanks of the radiator must be shielded to prevent injury from steam in the case of pipes, hoses or radiator failing. All pipes in the cabin area must be covered / lagged and shielded to protect driver in the event of a hose or pipe leak. No household carpet, cloth or similar material permitted to be used to wrap water pipes are to be as short as possible and shielded, and radiator outlet pipes must face the rear of the vehicle. Approved hose clamps must be used, and there are to be no joins in pipes in front of the radiator between it and the firewall.
- e) Radiators mounted in the cabin area must have overflow hoses going through the floor. If used, overflows bottles are to have a maximum capacity of 2 litres. If overflow bottles are mounted in the cabin area they must be fully shielded.
- f) Radiator cap must be lever vent type and must be shielded.
- g) Radiator in engine bay must be in original position. No cutting out of bodywork to make it fit. Radiator support panel is permitted only if running a radiator in the front. Bracing back to edge of sub frame permitted. Maximum material 25mm x 25mm x 3mm RHS tubing or angle iron. Bracing must be no wider than the radiator and must not protrude more than 50mm in front of the radiator, between it and front of the car.

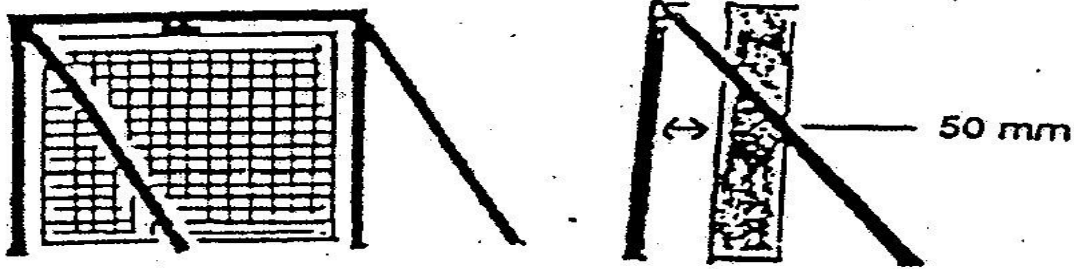

- h) Utilities with rear mounted radiators must add additional shields around radiator to ensure other drivers and other persons are protected in the event of a cooling or radiator failure.

## 15) EXHAUST SYSTEM

- a) Extractors and headers permitted for carburetted cars only.
- b) Exhaust must be within noise level requirements of each track. (Check before you attend)
- c) Mufflers must be fitted to the engine pipe which must be securely mounted and bracketed.
- d) Exhaust to extend and finish as a minimum past the rear of the driver's seat and must point away from all fuel and brake lines. Floor may be shaped to lift muffler. Exhaust system must not pass through the cabin.

## 16) FUEL TANK / LINE / TAPS

- a) The vehicles original OEM manufactured fuel tank is not permitted and must be completely removed.
- b) Fuel tank to be either an approved marine tank, or suitably manufactured tank of minimum 16G steel, stainless steel or 3mm aluminium. Maximum capacity 30 litres. Filler cap must have a tight seal.
- c) Commercially produced plastic racing fuel tanks permitted but must have an earth strap fitted from the plastic fuel cell filler neck to roll cage or chassis as an earth to prevent build-up of static electricity.
- d) **Jerry Cans not permitted.**
- e) Fuel tanks must be mounted in an upright position in a suitable frame and securely mounted. Contact area must be a minimum 30cm from rear and sides of boot area and must have rubber under all mounting points and straps to prevent metal to metal, aluminium to metal contact. Tanks to be isolated from driver by a steel firewall. Tank must be securely fastened. Boot must be able to be opened for scrutineering and inspection of fuel tank area. Filler neck of tank must be inside the boot area. Filler cap must have a tight seal.
- f) No openings in rear parcel shelf.
- g) Area beneath fuel tank must have adequate ventilation in the event of spillage during refuelling.
- h) A breather pipe is to be fitted to fuel tank and fitted with either a pig tail to go around tank in two (2) directions or a suitable one-way valve to seal in the event of a roll-over. Pick-up and breather pipes to be silver soldered or braised into tank. Overflow must be put through boot floor away

from exhaust. Fuel lines must be first grade fuel line or original system, securely fastened. Screw clamps only are to be used on fuel line connections.

- i) All fuel lines and electrical wiring must be separated and not taped together and must be fitted with grommets when passing through metal firewalls etc. and must be taped and secured where chaffing can occur.
- j) Fuel taps are optional but must be marked on/off.
- k) Fuel taps not permitted on EFI and fuel pump is to be mounted securely within the petrol tank area.

## 17) FUEL

- a) **Additives:** The introduction into the combustion chamber/s of additives, either in solid, liquid or gaseous form (e.g. Nitrous oxide) by any means is expressly forbidden.
- b) Fuel - petroleum ULP or PULP pump fuel only, maximum 98 octane RON (Research Octane Number). No additives, No avgas, No racing fuel, No methanol, No E85. Fuel must be supplied by commercial outlet through multi volume network via bowser pump. Fuel may be tested by any means available at any time as determined by the RSA.

## 18) ROLL CAGE

### General

- a) The purpose of the roll cage is to prevent the collapse of the cabin area under impact. The cage must extend from behind the driver's seat forward (**except utes**) to the windscreen area and incorporate protection for the driver's feet. The roll bars are to constitute a cage type framework, braced fore and aft. All roll cage bar-work is to be inside the body and within the cabin area. The roll cage is to enclose the driver and to be full width and full height of the cabin area.
- b) No bolts/rivets/screws or holes of any sort are to be put in any roll cage structural tubing in the cabin area, except as described for rub rails.
- c) All roll bar material must be of good quality mild steel, sizes for each bar as described in the following sections. Aluminium based materials not permitted Galvanized tubing or welding over threaded tubing not permitted in any structural bar work. Water pipe fittings or malleable fittings are not permitted.
- d) All bends to be made using a pipe bender with the correct size former with no evidence of crimping, wall failure or significant weakening.
- e) **NOTE:** Unless otherwise stated, all roll cage bars **including the Main Hoop bar must be made of one continuous length** of the appropriate material and built using fusion welding techniques only. Gussets may be required to welded joints.
- f) Roll cage pipe padding is recommended around / near driver area to cushion the effects of any impact.
- g) There are many variations in roll cage design mainly due to the different body shapes, especially in later models. These roll cage specifications describe the minimum elements that constitute an acceptable roll cage. Roll cages which exceed the requirements of the specifications through additional bars or the use of larger diameter tube are also acceptable provided all roll cage bar-

work is to be inside the body and within the cabin area, and the roll cage is passed as safe. If in doubt, contact the RSA or State technical officer for the class to get a ruling as covered in this books 'Interpretation' section.

- h) The specifications for the minimum elements of a roll cage follow. Unless otherwise specified, all bars are compulsory. Any additional roll cage bars must be of roll cage material, i.e. Minimum AS1163 Gr300 38mm OD x 3.0mm wt. CHS.
- i) If unsure in any aspect of the design or assembly of cage or any other roll cage compliance as stated within, contact the RSA for clarification. **NOTE:** This applies especially when using, modifying or retro-fitting an earlier built existing cage.

## 1) Floor Bars

Material: Minimum AS1163 Gr300 38mm OD x 3.0mm wt. CHS or  
Minimum 50mm x 50mm x 3mm RHS or  
Minimum 50mm x 50mm x 3mm Angle iron

The floor bars run from front to rear inside the cabin on each side as close to floor as practicable. At a minimum they must extend from the rear of the main hoop to front of the foot protection on the driver's side and the front of the forward roll cage leg on the passenger's side. They may extend as far forward or back as possible (e.g. to the rear wheel arch) as long as they are within the cabin area. If using CHS or RHS they must be securely welded to the floor panels/sills. If using angle iron, they must be welded or bolted to the floor panels/sills using at least four 12mm steel bolts through the sub frame and using 100mm x 100mm x 3mm minimum plates under the floor.

## 2) Cross Braces

Material: Minimum AS1163 Gr300 38mm OD x 3.0mm wt. CHS.

The cross braces run from side to side between the floor bars as close to floor as practicable. The rear cross brace must line up with the main hoop. The front cross brace must be in the area from the front of the seat to the firewall. There are multiple options for front cross brace designs – refer to roll cage diagrams.

The front spreader bar is to be no further back than 100mm from the front of the roll cage. This is to prevent the cage from folding inwards in the event of a T-Bone collision.

## 3) Main Hoop

Material: Minimum AS1163 Gr300 38mm OD x 3.0mm wt. CHS.

The one-piece main hoop runs vertically from the floor bars on each side of the cabin following the profile of the doors and roof behind the driver and be within 50mm of the sides of the roof at the narrowest point.

## 4) Main Hoop Brace

Material: Minimum AS1163 Gr300 38mm OD x 3.0mm wt. CHS.

A one-piece diagonal brace must be fitted in the main hoop behind the driver's head from top right to bottom left. The top right mounting point must be within 250mm of the corner of the main hoop.

**Must be mirrored on passenger side bar work if passenger seat fitted.**

The use of a two-piece main roll hoop diagonal brace is permitted only if a full length left to right one-piece seat back/shoulder belt mount bar between main roll hoop down legs is used as shown below. The diagonal brace must be fitted inside the main hoop behind the driver's head from top right to bottom left. The top right mounting point must be within 250mm inward of the top right-hand corner of the main hoop.

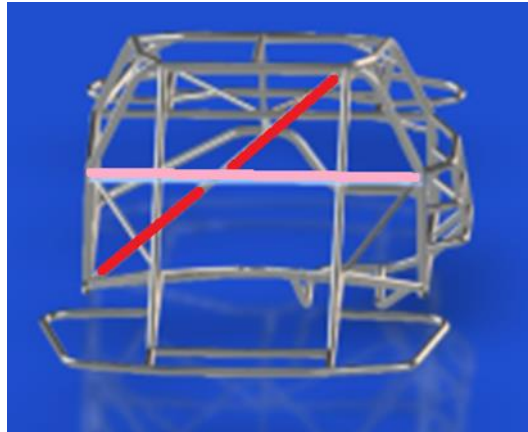

### **Main Hoop Cruciform Brace (optional)**

Material: Minimum 32mm OD x 3.0mm wt. CHS.

A second brace may be fitted to form a crucifix with the main hoop brace. This brace runs from top left to bottom right.

### **5) Seat Back Support**

Material: Minimum AS1163 Gr300 38mm OD x 3.0mm wt. CHS.

The seat back support runs horizontally from the main hoop brace to the main hoop. It is also used as a seat belt mounting point for the shoulder belts.

**Must be mirrored on passenger side bar work if passenger seat fitted.**

### **6) Roll Cage Legs**

Minimum AS1163 Gr300 38mm OD x 3.0mm wt. CHS.

The one-piece roll cage legs run from the top corners of the main hoop to the floor bars near the front door pillars. They must follow the A pillar line in the windscreen area, following the line of the A pillars.

Exception: Cars with severe rake of the windscreen. Angle of roll cage A pillar bar to be of not less than 45 degrees down from roof bar. May require a quarter window bar to be fitted. If a pillar bar does not follow A pillar line and is 45 degrees, additional sub frame cross brace from front of foot protection to LHS is required.

**Exception:** Cars with severe rake of the windscreen. Angle of roll cage A pillar bar to be of not less than 45 degrees down from roof bar. May require a quarter window bar to be fitted. If a pillar bar does not follow A pillar line and is 45 degrees, additional sub frame cross brace from front of foot protection to LHS is required.

### **3rd Roll Cage Leg (optional)**

Material: Minimum AS1163 Gr300 38mm OD x 3.0mm wt. CHS.

A 3rd roll cage leg running from the centre of the main hoop to the centre of the front cross brace may be fitted as an alternative to the centre roof bar and the centre windscreen bar. If this bar is fitted, the top and bottom windscreen bars may be fabricated in two pieces (one on each side of the 3rd roll cage leg).

## 7) Quarter Window Bars

Material: Minimum 25mm OD x 3.0mm wt. CHS.

A quarter window bar, if required because of excessive rake or a long roll cage, must be fitted on both sides and installed from the top NASCAR bar to roll cage leg at top half of pillar.

## 8) Top Windscreen Bar

Material: Minimum AS1163 Gr300 38mm OD x 3.0mm wt. CHS.

The top windscreen bar runs between the roll cage legs at the top of the windscreen area. It must be within 50mm of roof and 100mm of windscreen at front roll cage leg on side elevation.

## 9) Lower Windscreen Bar

Material: Minimum AS1163 Gr300 38mm OD x 3.0mm wt. CHS.

The lower windscreen bar runs between the roll cage legs at the bottom of the windscreen area.

## 10) Centre Roof Bar

Material: Minimum 32mm OD x 3.0mm wt. CHS.

The centre roof bar runs from the centre top of the main hoop to the centre of the top windscreen bar.

## 11) Centre Windscreen Bar

Material: Minimum 25mm OD x 3.0mm wt. CHS.

The centre windscreen bar runs from the centre of the top windscreen bar to the centre of the bottom windscreen bar.

**Additional bar - lower windscreen bar to cross brace - recommended** It is recommended that an additional bar of 38mm OD x 3.0mm wt. CHS be fitted between the lower windscreen bar and the forward cross brace if the cross brace is located sufficiently forward in the cabin so this bar is vertical or close to vertical. This bar is optional.

## 12) Driver's Side Door Bars & Spacers

Material: Minimum AS1163 Gr300 38mm OD x 3.0mm wt. CHS.

On the driver's (right) side three (3) horizontal side bars, curved out ('NASCAR' style) to the door skin, must be fitted between the main hoop and the front roll cage leg, evenly spaced between the window sill and the floor bar.

A minimum of two vertical spacer bars, evenly spaced between the front and rear roll cage legs, must be fitted between the floor bars and the top horizontal bar. The top horizontal NASCAR bar will be within 50mm of the window sill.

Optional: One (1) only middle (not the top bar) driver's nascar door bar may extend or be extended through to the front of the rear wheel arch area and attach to the main hoop via a short bar forming a 'T' junction. This bar is not to be used as an inner rub rail mount.

**\*\*LEFT HAND SIDE ROLL CAGE (PASSENGER SIDE) TO BE MIRROR OF DRIVERS SIDE IF PASSENGER SEAT FITTED. Including foot protection, anti-spear plate and head plate.**

### 13) Passenger's side door bars – NASCAR Option

Material: Minimum AS1163 Gr300 38mm OD x 3.0mm wt. CHS.

On the passenger's (left) side two (2) horizontal side bars, curved out ('NASCAR' style) to the door skin, must be fitted between the main hoop and the front roll cage leg, evenly spaced between the window sill and the floor bar.

A minimum of one vertical spacer bar, evenly spaced between the front and rear roll cage legs, must be fitted between the floor bars and the top horizontal bar. The top horizontal NASCAR bar will be within 50mm of the window sill.

**Optional:** One (1) only middle (not the top bar) passenger's NASCAR door bar may extend or be extended through to the front of the rear wheel arch area and attach to the main hoop via a short bar forming a 'T' junction. This option is only available with the NASCAR option for passenger door bars. This bar is not to be used as an inner rub rail mount.

#### Passenger's side door bars – Alternative

Material: Minimum AS1163 Gr300 38mm OD x 3.0mm wt. CHS.

On the passenger's (left) side one (1) straight (not curved) horizontal side bar, must be fitted between the main hoop and the front roll cage leg, within 50mm of the window sill.

An additional diagonal bar may be fitted (shown in diagram) between the main hoop and the front roll cage leg under the horizontal door bar from rear to corner to bottom front corner.

### 14) Rearward Brace Bars (optional)

Material: Minimum 34mm x 3mm wt. CHS

The rearward brace bars run from the top rear main hoop down onto cabin or boot floor subframe, firewall, parcel tray or wheel arch areas (approx. 45 degrees) and may be crucifix. Bars in boot area must terminate at least 300mm inward from rear boot panel. Bars may attach down to rear bumper return pipes (if fitted). They must attach to the rearward side of the main hoop within 100mm of the centre of the top radius.

### 15) Head Plate

Material: Minimum 3mm steel plate

A full head protection plate must be fitted to fully cover the area between the main hoop and top windscreen bar from the centre roof bar to the top of the roll cage leg on the drivers' side. When sitting, and belted in seat, there must be a minimum of 50mm clearance between helmet and head plate. Steel plate to be (stitch or fully welded) on.

**Must be mirrored on passenger side bar work if passenger seat fitted.**



## 16) Front Barwork

Material: Minimum AS1163 Gr300 38mm OD x 3.0mm wt. CHS.  
Maximum 42.5mm OD x 3.2mm wt. CHS.

**Optional:** Front bar work permitted from the internal roll cage into the engine bay area.

The attachment point at the internal roll cage may be either:

- the lower windscreen bar,
- the lower centre windscreen bar below the lower windscreen bar,
- the front floor cross brace or,
- the front roll cage legs forward of the A pillar.

The attachment point in the engine bay may be either:

- the suspension towers (one bar per tower), and/or
- the chassis rail or the front pipe bumper bar returns.

**Optional:** Front bar work permitted from the suspension towers to chassis rail or front pipe bumper bar returns behind the radiator support panel and a minimum of 300mm behind the front pipe bumper, maximum 38mm OD x 3.2mm wt. CHS. Max. 100mm x 100mm x 3mm plate may be welded to towers for support.

## 16b) Front Halo Bar

Material: Maximum 38mm OD x 3.2mm black pipe.

Single Halo style front protection bar work, with radius corners only. To run from dash bar on roll cage through firewall, can go inside or outside of strut tower to radiator support panel, cross then back down to other side of roll cage dash bar (like a halo bar). May run on top of the radiator support panel as in this photo but must be under the bonnet.



Halo bar to have 2 tabs welded to each side along the inner guard 50mm x 50mm x 4mm thick to help secure the bar to the front of the car.

## Roll Cage Diagrams

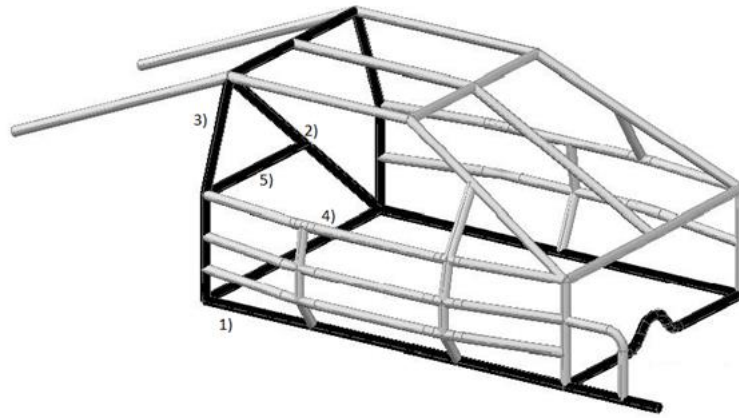

- 1) Floor bars
- 2) Main Hoop brace
- 3) Main hoop
- 4) Cross brace
- 5) Seat back support

### Front Cross brace design options

A. Old Style Cross Brace

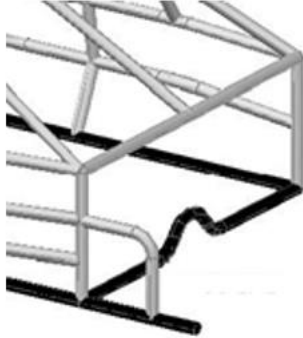

B. Later models with higher tunnels



C. 'Fuller' Cross Brace



D. As used in other divisions

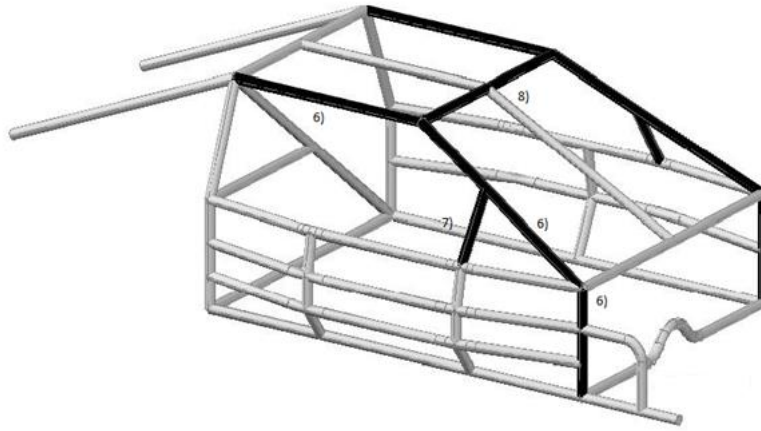

- 6) Roll cage leg
- 7) Quarter window bar
- 8) Top windscreen bar

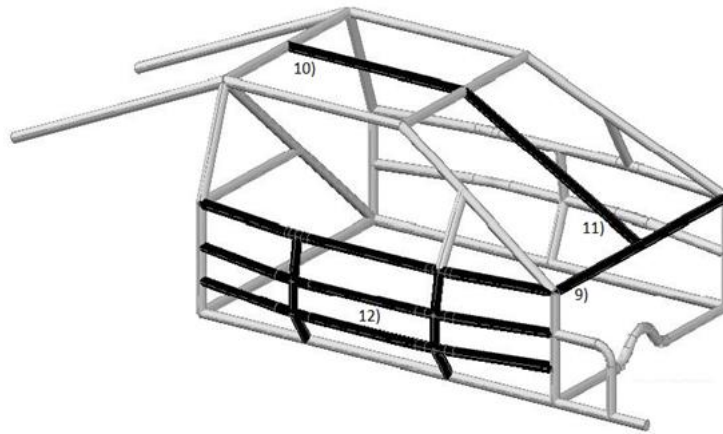

- 9) Lower windscreen bar
- 10) Centre roof bar
- 11) Centre windscreen bar
- 12) Driver's door bars and spacers

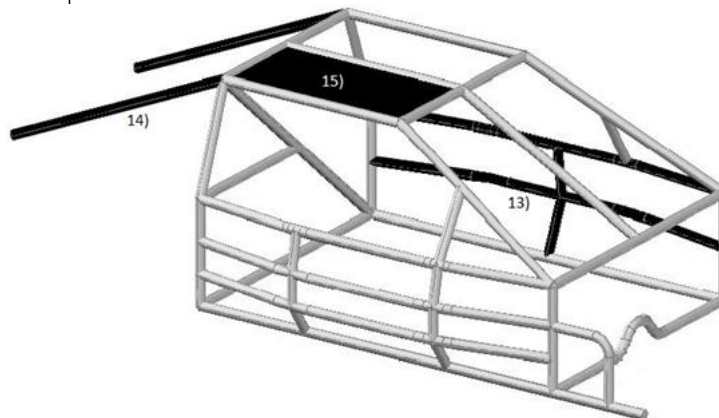

- 13) Passenger door bars (NASCAR option)
- 14) Rearward brace bars
- 15) Head pate

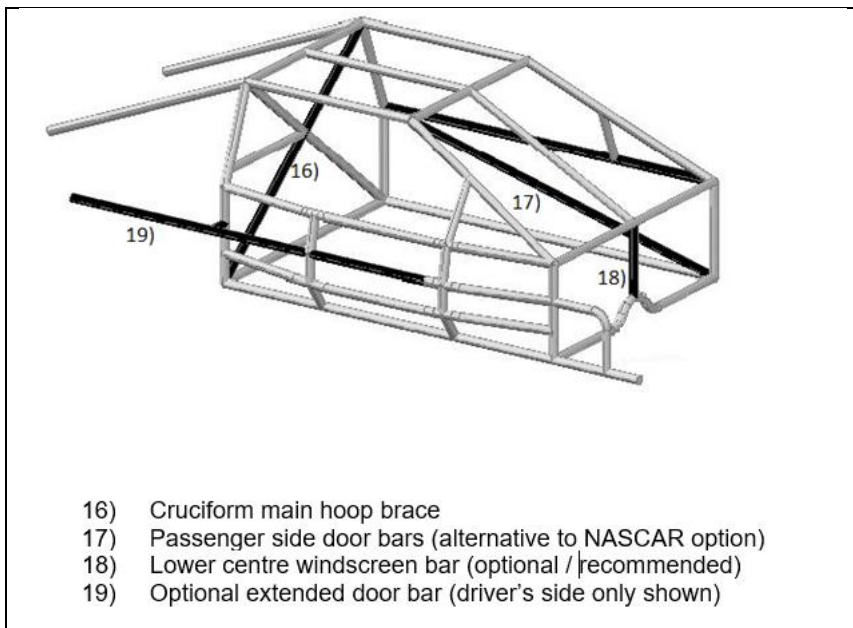

Bumper-to-bumper barwork only approved for later model cars. VN and EA onwards (does not show optional front barwork to suspension towers as described in section 16 above). The barwork from the bumpers to the cage is described in Bumpers section, ref 12.g and 12.h.

The 'halo bar' style roll cage as shown above is permitted as an option to the roll cage designed described in the main section. The 'halo bar' extends forward along the inside of the door frame following the roof line from the main hoop to the top of the windscreen and back to the main hoop on the opposite side. The forward legs run from the 'halo bar' down the inside of the A-Pillar and inside door frame to the floor bars. Material to be as per roll cage barwork (minimum AS1163 Gr300 38mm OD x 3.0mm wt. CHS).

## Anti-Spear Plate

Material: Minimum 3mm steel plate

Either a one-piece plate or 3 individual plates of 3mm steel must be fitted to form an anti-spear external cage plate on the driver's side NASCAR bars from floor-line to window sill bar, forward of the first vertical door bar to the front leg of roll cage. Not to be lightened by drilling. The anti-spear plate may be extended to 2<sup>nd</sup> spacer bar on the driver's side NASCAR bars as an option.

Steel plate: to be a minimum stitch welded (preferably fully welded) to roll cage.

**Must be mirrored on passenger side bar work if passenger seat fitted.**

## Foot Protection

Material: Minimum 3mm steel plate

Minimum AS1163 Gr300 38mm OD x 3.0mm WT CHS.

Foot protection bar work is mandatory if drivers' feet are past the A pillar bar whilst the driver is seated in the car in race position. The minimum requirement for foot protection a curved bar of minimum 38mm OD x 3.0mm WT extending forward from the A-pillar bar to the floor bar in the footwell of the driver's side. The internal area formed by the foot protection bar must be filled with minimum 3mm steel plate either stitch or fully welded to the foot protection bar.

If practical, straight leg fitment of driver's side A-pillar bar through to subframe floor bar intersecting at firewall, is permitted as an option for the foot protection bar.

An optional support bar min 25mm OD x 3mm WT maybe fitted from the foot protection bar to bar work to the left.

**Must be mirrored on passenger side bar work if passenger seat fitted.**

Anti-Spear Plate / Foot Protection Diagram

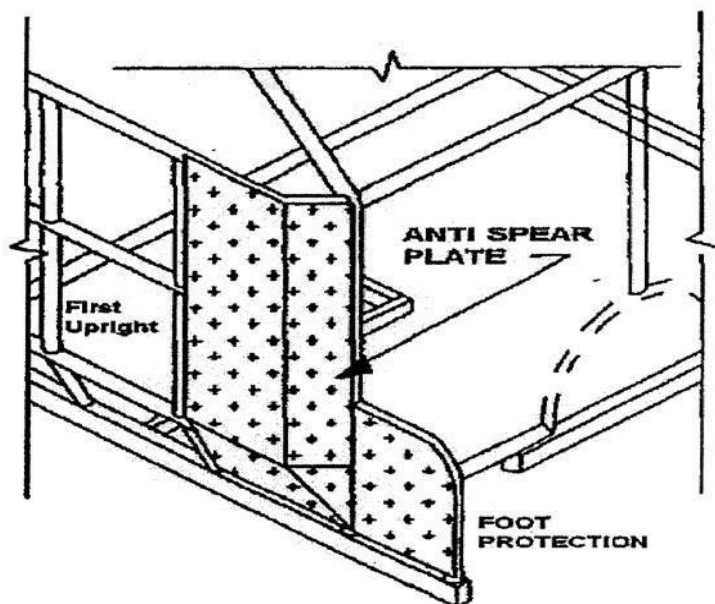

## 19) SUSPENSION

- a) Suspension must be standard as per base model and shape (i.e. sedan to sedan, wagon to wagon, ute to ute. 4cyl. Motor must use 4cyl. Suspension and 6 cyl. Motor must use 6cyl. Suspension). Standard springs, original sub frame and wishbone must be used. No aftermarket springs or sway bars permitted. No lowering or jacking permitted by use of weights. Random checks after scrutineering will happen to help police this matter and a severe penalty will be given if found guilty.
- b) Manufacturers or equivalent gas or oil Shock Absorbers allowed. No air shocks permitted. A non-adjustable spreader bar is permitted for McPherson Struts, but must not be used as a body strengthened. Maximum material 25mm x 25mm x 3mm. Must be between towers only - not back to firewall. Limiting of suspension travel by use of chains not permitted.
- c) Commodores - McPherson Strut suspension can have camber castor adjusters in the top of the Strut or aftermarket camber pins for bottom control arms not both. A non-adjustable spreader bar is permitted for McPherson Strut suspension only. Maximum material 25mm x 25mm x 3mm RHS. Must be between towers only - NOT BACK TO FIREWALL.
- d) **Falcons EA onwards** - Camber pins and castor adjusters are permitted. Aftermarket camber pins and plates (no homemade plates) must be used. The measurement from the inside of the cross member to the centre of original bolt hole is 50mm. The camber plate has an elongated slot. The original bolt hole has to be in the centre of the elongated slot. Camber plate is to be welded to the cross member. A movement of 10mm left or right is allowed. Total measurement 60mm, (refer diagram). Hole only allowed with Camber Pin, otherwise to remain standard.

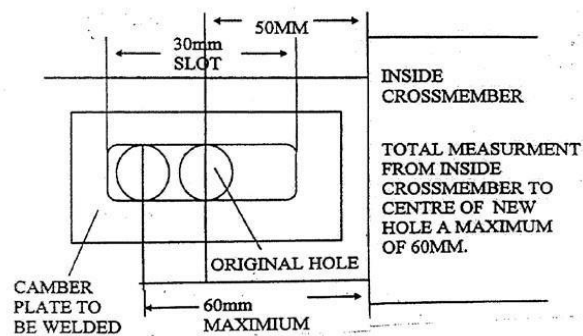

- e) Rose Joint). No chain or exhaust clamps permitted. Centre of steering wheel must be padded. Factory type thick centred wheels do not require padding. No cutting or welding of steering components allowed, other than for fitting quick release steering wheel.
- f) Quick release steering wheels optional. Steering wheel quick- release hub to be professionally manufactured. To be made of aluminium or steel - no plastic. It is recommended that the retaining pin be integral of the hub. Steering position to remain standard.
- g) Rose Joint permitted on top mounting only. Bottom of steering shaft to be firmly located at floor and in original position. A collapsible shaft must be used, and the Rose Joint must be securely retained on the shaft with locking collars either side of the Rose Joint, with shaft recessed for grub screw to be retained circlips not permitted. Must be mounted on roll cage cross bar, extension for Rose Joint to be made of roll cage pipe only.
- h) Heim joints are allowed but shaft must remain collapsible and only on vehicles that have collapsible steering.

## 20) WHEELS/TYRES

- a) No racing tyres, no racing retreads, and no off-road rally tyres allowed. Tyres must meet minimum 60 durometer reading. Radial tyres only. All details are to be visible in OEM markings on tyre side walls, (e.g. 225/65 R15H or 215/70 R15H).
- b) Rim size is optional up to and including 16" diameter. Cortina's can use up to 15" wheels with 5 stud conversion. Wheels must be in good condition and free from cracks. Standard manufactured steel wheels including after-market steel wheels permitted. Welded wheels optional. Mag or Alloy wheels may be used but must be of one-piece construction. Composite type wheels NOT acceptable (Composite means wheels that are made of different materials).
- c) Centre hole of all rims should match the Hub so that studs don't carry all the weight of the car. Wheel studs must be a minimum of 11mm. Cortina axles may be modified to strengthen flanges. Wheel weights not permitted.
- d) Wheel spacers permitted, maximum 10mm per wheel. Spacers must be a 'store bought' item not homemade. Suitable long wheel studs must be used with spacers.
- e) Tyre / Rim combination must not extend outside of the original bodyline of all wheel arch / guard areas on all vehicles.
- f) Note- The general ruling on this is taken from the top outside edge of the tyre/rim combination (not the bottom outside edge) in relation to the outermost point of the wheel arch/ guard. Scrutineers are to use obvious discretion and judgment on each situation.

## 21) WHEEL ARCHES

Wheel arches may be opened up to no more than 100mm from original opening.

## 22) BRAKES

Race cars must be 'fitted with effective brakes on all four wheels. No adjustable brake taps or similar permitted. Not necessary to lock up.

## 23) PEDALS

All pedals to be mounted in original position. No extensions to pedals allowed.

## 24) STEERING

- a) Left-hand drive not permitted. Steering must remain in standard and sound condition Steering position to remain standard. Modifications are not permitted to any steering components unless specified.
- b) Power Steering optional provided it is as per production line for model. Late model cars mounting to Scrutineer's satisfaction. Standard pulleys must be used. Aftermarket power steering oil cooler permitted, (1) one only, must be mounted in engine bay.

- c) Original or sports type steel wheels approved. Wire spoke, or wood rim steering wheels not permitted. Centre of steering wheel must be padded. Factory type thick centred wheels do not require padding.
- d) Steering column must pass through a steel loop 12mm thick, bolted or welded to the dash bar (loop not required if using a Rose joint). No chain or exhaust clamps permitted. No cutting or welding of steering components allowed, other than for fitting quick-release steering wheel.
- e) Quick-release steering wheels optional. Steering wheel quick-release hub to be professionally manufactured and to be made of aluminium or steel – no plastic. It is recommended that the retaining pin be integral to the hub.
- f) Rose joint permitted on top mounting only. Bottom of steering shaft to be firmly located at floor and in original position. A collapsible shaft must be used, and the rose joint must be securely retained on the shaft with locking collars either side of the rose joint, with shaft recessed for grub screw to be retained – circlips not permitted. Must be mounted on roll cage cross bar, extension for rose joint to be made of roll cage pipe only.
- g) The use of professionally made after market steering column mounts as shown below is permitted. Mounts must be in original position and not to be used to offset steering position. Must be securely mounted to lower windscreen bar.



## 25) TRANSMISSION

- a) Ratios are optional but must be from same make or optional model.
- b) Standard factory gearbox must be used as per model, but three (3), four (4) or five (5) speed gearboxes can be interchanged but must be from same parent manufacturer. Straight or split tail shafts may be used to suit gearboxes and differentials. Race vehicles must have a minimum of two (2) forward and one (1) reverse gears. Gear lever shall be rendered harmless by the use of a suitable knob, handle etc.
- c) The following options are permitted for four(4) speed electronic BTR auto transmissions for first and second gear:
  - Hard wire into the factory transmission harness using only the green with white and green with black trace wire and putting only power from your ignition switch to green with white trace and adding a toggle switch with both these wire on it as close to the gearshift as possible for first and second gear.
  - Use the BTR 4 speed manual controller (otherwise known as the black box) which is hard wired into the transmission harness.



- d) A steel strap or chain is to be secured under the front of the tail shaft 150mm to the rear of the front universal joint. Loop is to have a 50mm clearance below tail shaft. Materials to be a minimum 5/16" (5mm) chain or 5mm x 25mm strap.
- e) Neutral/inhibitor safety switches or brake pedal switches must be installed and working on all auto transmission cars.

## 26) DIFFERENTIAL

- a) Ratios may be altered if crown wheel and pinion only are changed. Must fit original model housing, not complete from another model. From 4- and 6-cylinder models only.
- b) No V8 or aftermarket crown wheel and pinion. No Ford 9" diffs.
- c) There will be no quick-change diffs. permitted. All diffs to be locked. Four (4) wheel drive not permitted. Rear axle bearing retaining collar rings to be tack welded to axle. Maximum two (2) tacks 5mm long, using a small diameter low hydrogen rod on low amperage. If axle is lost and it found that this has not been done, driver will be penalized.

## 27) ENGINE

- a) Engine capacity 274 c.i. absolute maximum.
- b) Manufacturers markings to remain on engine block castings. Engine to remain standard per model, with everything operational, with the exception of fan blades (not required).
- c) Engine position to remain standard as per model. Cross members may be interchanged to suit motor, but no cutting or welding permitted. Solid engine mountings to be used. Bolted, welded or chained.
- d) 4- and 6-cylinder engines only. Rotary, Turbocharged, Supercharged or any other sports type engines not permitted. No model built specifically for a 4-cylinder motor will be permitted to run a 6-cylinder motor. Engines up to 1986 may be used. Engines are interchangeable in same make of car. Engine parts are not interchangeable (i.e. Holden red motor parts cannot be used in a blue motor and vice versa ... this also applies to other makes and models).
- e) No porting or polishing of Head, Inlet Manifold or Extractors permitted. This means no interfering or modifying to fit Carburettor or Extractors.
- f) Base model valves and port sizes to be retained. Standard Con Rods and standard Pistons (up to 60thou) may be used. Crankshaft to remain standard. Cam followers to remain standard as per year model. Standard Cam lift to be used as per specifications.
- g) Standard Distributor to be used without any modifications to fit. No performance enhancing types permitted. Aftermarket standard equivalent steel Flywheel and Clutch may be used- no lightening. Inspection cover is optional. Hydraulic and cable Clutches are interchangeable.
- h) Oil coolers permitted for automatic gear boxes. Engine oil coolers permitted if factory fitted on production base model. No aftermarket auxiliary oil coolers permitted. Crankshaft, Alternator, Power Steering and Water Pump Pulleys must remain standard as per model. Pulleys.
- i) Electric Water Pumps not permitted. Idler pullies(optional)for power steering only.

- j) Factory Manifolds and Extractors accepted for model.
- k) Early model motors and heads may come forward to a later model car.
- l) Holdens may use up to and including the 3.3 black motor. Fords may use up to and including the 4.1 alloy head crossflow motor.

## 28) EFI ENGINES

- a) EFI engines maybe used in late model bodies “only” carburettor engines (optional) VN-VS for Holden’s.
- b) EA-EL for Fords/
- c) Holden’s to run Buick engines “only” – no eco-tech engines allowed.
- d) Fords to run 4.0lts up to EL engines with EA-ED intake manifolds.
- e) Engines to remain standard, with standard exhaust manifolds no extractors permitted. Automatic gearboxes “only”.
- f) MUST RUN RSA SEALED COMPUTER.
- g) Engine must be mounted in original position without modification using solid engine mounts, or resilient engine mounts with minimum 6mm chain restraints.
- h) EFI engines are to be standard with only modifications / additions and clarifications as mentioned in this current spec book and any other subsequent RSA approved and club notified revisions regarding EFI engines.
- i) The only car and engine combinations permitted to use Fuel Injection (EFI) are as follows:

**HOLDEN:** Holdens may run up to VT Commodore (2000) bodies and EFI engines as follows:

- 1) Commodore S1 and S2 3.8lt engines may be used in VN to VT models.  
Must use VN-VP computer and wiring loom, DFI module and coil pack.  
Valve sizes: Inlet 43.4mm Exhaust 37.8mm Throttle butterfly size 60mm.  
Injector part numbers permitted: 0280 150 901 / 0280 150 960 / 0280 150 973 / 0280 150 917 / 0280 155 777
- 2) Commodore Ecotec 3.8lt engines may be used in VS to VT models only.  
Must use VN-VP computer, wiring loom, DFI module and coil pack.  
Ecotec engines must use VN/VR map sensor.  
Valve sizes: Inlet 45.5mm Exhaust 38.5mm Throttle butterfly size 64mm  
Injector part numbers permitted: 0280 150 901 / 0280 150 960 / 0280 150 973 / 0280 150 917 / 0280 155 777
- 3) Later model Commodore Ecotec II 3.8lt engines may be used in VT model only.  
Must use VN-VP computer, wiring loom, DFI module and coil pack.  
Ecotec engines must use VN/VR map sensor.  
Valve sizes: Inlet 46.5mm Exhaust 38.5mm Throttle butterfly size 64mm  
Injector part numbers permitted: 0280 150 901 / 0280 150 960 / 0280 150 973 / 0280 150 917 / 0280 155 777

## FORD

All Ford EFI engines must use:

- 1987-90 EA-EB pre-smartlock computer,
- standard or aftermarket standard equivalent distributor and coil,
- multipoint (log type) injection manifold.

Early model motors and heads may come forward to a later model car – unless otherwise mentioned.

Fords may run up to AU Falcon (2002) bodies and EFI engines as follows:

- 1) Falcon EA 3.9lt to ED 4.0lt engines may be used in EA to AU models.  
Valve sizes: Inlet 47mm, Exhaust 39mm Throttle butterfly size 64mm  
Injector part numbers permitted: 0280 150 736 / 0280 150 790 / 0280 155 844
- 2) Falcon EF 4.0lt to EL 4.0lt engines may be used in EF to AU models only.  
Valve sizes: Inlet 47mm, Exhaust 39mm Throttle butterfly size 64mm  
Injector part numbers permitted: 0280 150 736 / 0280 150 790 / 0280 155 844
- 3) Falcon AU 4.0lt engines may be used in AU models only.  
AU block, EA-EL head permitted – if used the head is to retain the original head valve sizes only.  
Valve sizes: Inlet 47mm, Exhaust 41mm Throttle butterfly size 64mm  
Injector part numbers permitted: 0280 150 736 / 0280 150 790 / 0280 155 844

### **Fuel Injected Engines are permitted using the following restrictions:**

- 1) All computers must be standard OEM, purchased and sealed by a RSA approved organization, currently either EFI Spares or Automotive Service Solutions. Owner supplied approved standard OEM computer for RSA testing and approved sealing permitted. No approved or damaged seal etc. = no racing. Possible re-inspection, re-testing and re-sealing of 'damaged' ECU will be the owner's responsibility including costs if applicable. Computers / ECU units may be interchanged with a sealed replacement unit by a RSA / club official for a race meeting at any time. Failure to comply will result in minimum exclusion from that race meeting and other penalties may apply.  
2) Any person found to have altered or added to any component of a computer / ECU will face a suspension of up to 2 years or as mentioned and determined under the applicable rules in the current (at point in time) version of Speedway Australia Racing Rules.
- 3) All ECUs are to be fitted and protected in such a way as to limit ECU damage and the sun / water / dirt deterioration of the ECU seals. Suitable encasing of the ECU is not only acceptable but recommended as long as ease of inspection and removal is still possible at any time.
- 4) Standard sized OEM injectors are to be used for make and model of engine or fuel injection system used. Inside diameter not to be increased or decreased.
- 5) Rev limiter must remain OEM and must not exceed OEM limit. The maximum revs attainable (peak revs) by engine may be checked at any time by a Scrutineer using any current (at point in time) method, technology and procedure as approved by the RSA.
- 6) All standard sensors except oxygen and cooling sensors must be fitted and operating.
- 7) Electric fuel pumps must automatically shut off when engine stops running.
- 8) Base model engines only (i.e. No Turbocharged, Supercharged, VCT, XR6 or Tickford engines or heads). No forced induction.

- 9) Engines must remain externally visually standard with all components fitted unless otherwise mentioned. Exceptions are air conditioning equipment and air cleaner assembly.
- 10) Engine must be positioned in the engine bay with the rear face of the block in the same position as the original engine.
- 11) All casting marks must remain.
- 12) Crankshaft must be standard OEM for the engine. No offset grinding.
- 13) Conrods must be standard OEM for the engine. No lightening or polishing.
- 14) Pistons must not be machined or lightened. No additional fly-cuts/valve reliefs permitted, noting that standard Falcon pistons have a valve relief on the inlet side.
- 15) Rocker gear must remain standard OEM type for the engine.
- 16) Sump must be OEM and remain externally visually standard.
- 17) All pulleys must remain OEM for the engine block and all fan belts must remain the same type and profile as OEM for the engine block. Exception: EA-ED EFI may run the single serpentine belt configuration the same as EF-EL.
- 18) Return springs must be fitted to each butterfly shaft. OEM inbuilt type is acceptable.
- 19) Fuel pump must be passenger car type.
- 20) Fuel Tank must be professionally made with high pressure line and return line fitted into top of fuel tank. Breather pipe as per normal specifications.
- 21) A flexible fuel line section must be fitted within 75mm of fuel tank, and all fuel lines to be securely fixed in position. Barbed fittings of the correct size must be used in conjunction with screw type clamps when connecting flexible fuel line. (Genuine SAE R6 fittings and hose accepted). 23) Appropriately rated high pressure reinforced fuel Injection hose and fittings are to be used only. Securely fixed flexible fuel hose or OEM type 'Bundy' steel tubing may be used through the car or under the car.

Optional - 'Push Lock' fittings and SAE 100 R6 spec fuel hose (examples of both pictured below) are permitted and may be used as a combination without hose clamps. Note that the correct spec hose must be used with this type of fitting, and the fitting is unsuitable for use with standard EFI or Carby fuel hose.

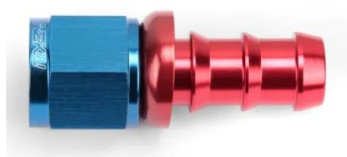

- 24) Flywheels, pressure plates and clutch plates must remain OEM or standard replacement type.
- 25) Any engine component or ancillary item not specifically mentioned is to be OEM for the engine block or standard aftermarket equivalent.
- 26) The following modifications **ARE PERMITTED** for EFI engines:

- a) Protective wire gauze or air cleaner to be fitted over air intake to prevent entry of foreign objects to throttle body, and also to act as a flame trap.
- b) Ignition / spark plug leads up to 8mm outside diameter.
- c) 0.060" maximum oversize on standard bore.
- d) 0.060" maximum facing off head surface.
- e) Maximum 2-cylinder sleeves per engine block.

27) The following **ARE NOT PERMITTED** for EFI engines:

- a) No Porting or polishing of head /s or any inlet manifold component.
- b) No Head studs.
- c) No Lightened flywheels.
- d) No Angle facing of head and/or block surfaces.
- e) No Forced induction.
- f) No Removal of any balance shaft.
- g) No Performance type harmonic balancers.
- h) No Performance enhancing ignition systems.
- i) No Modification to throttle body or butterfly.
- j) No Solid lifters.
- k) No Balancing of the engine / components permitted.

## 29) CARBURETTOR

- a) One single or dual throat manifold.
- b) No aftermarket carburettor or manifold to be used. An extra return spring must be fitted to carburettor main throttle shaft.
- c) Ford 4.1 Crossflow-Alloy Head-Factory Manifold with 2-barrel OEM Webber Carby, or factory single Carby.
- d) Ford 4.1 Crossflow- Cast Head- Factory Manifold with factory single barrel Carby.**ONLY**.
- e) Ford 250- 2V- Factory Manifold with 2-barrel Stromberg or Carter.
- f) Holden 3.3 Blue Motor- Factory Manifold with 2-barrel Variajet Carby **ONLY**.
- g) Holden 202 or 3.3 and all Red Motors and all other red Motors- Factory Manifold with 2-barrel Stromberg or Carter or single factory Carby.
- h) Valiant 215, 245, 265 and Hemi Motors-Factory Manifold with 2-barrel Stromberg or Carter or single factory Carby.
- i) Standard Factory Inlet Manifold must be used. Factory Manifolds must not be modified to accept different Carbys or Heads. Carbys must not be modified to suit different Manifolds. All other models as per base production year. Carburettor throats to remain standard (i.e. no porting or polishing). Two return springs must be fitted to Carburettor main throttle shaft. Throttle linkages can be changed to cable.
- j) Sports Air Filters can be used instead of standard. Inlet manifold must not be cut, shortened or welded other than minor corrosion repair which may be checked by removal of carburettor and or manifold from engine. An adaptor plate for carburettor can be used. Not to be used as a spacer. No more than 25mm maximum, to be bolted and must be removable.

- k) Maximum one (1) gasket per seal to be used. Cable may replace throttle linkages. Air cleaner optional, sports type can replace standard.

### **30) WINGS**

- a) Wings are permitted at the discretion of the Club, Promoter and as per track regulations. Maximum length 1465mm, minimum length 735mm. Maximum height 710mm, minimum height 355mm from highest point of the roof. Maximum width to be no wider than original roof gutters. Must be securely mounted on the roof only.
- b) Roof wings not permitted at blue ribbon events.

### **31) SPOILERS**

- a) No body kits permitted, but rear spoilers may be fitted. There are many makes and models of spoilers, so any final interpretation of fitment will be up to the RSA Executive/Tech officer. If unsure consult before fitting.
- b) Rear spoilers are allowed but must be polycarbonate, fiberglass or plastic only and of a mass-produced store-bought item. No steel, aluminium or homemade will be allowed. Maximum height must not to exceed 150mm from top of boot lid to uppermost point of spoiler.
- c) Spoiler to not extend past the line of the rear quarter panels and must be firmly fixed. Hatchback spoiler not to exceed 150mm in height from lowest point of hatch.

## **Appendix 1 – Limited Approvals 2024-25 season**

The following optional specifications have been approved until the date of the 2025 AGM. Any permanent approval after that date is dependent on these specifications being passed at the 2025 AGM.